

TABLE 미장착 - 표준품

Clamp SPEC.		
Axis	적용 유압력	Piston 추력
S01 A Axis	25 kgf/cm ²	3,060 kgf
S02 C Axis		2,380 kgf
S03 Support Axis		2,190 kgf
Clamp 사용 압력 주의 할 것.		
Clamp 관련 Manifold Label 압력 표기 주의		

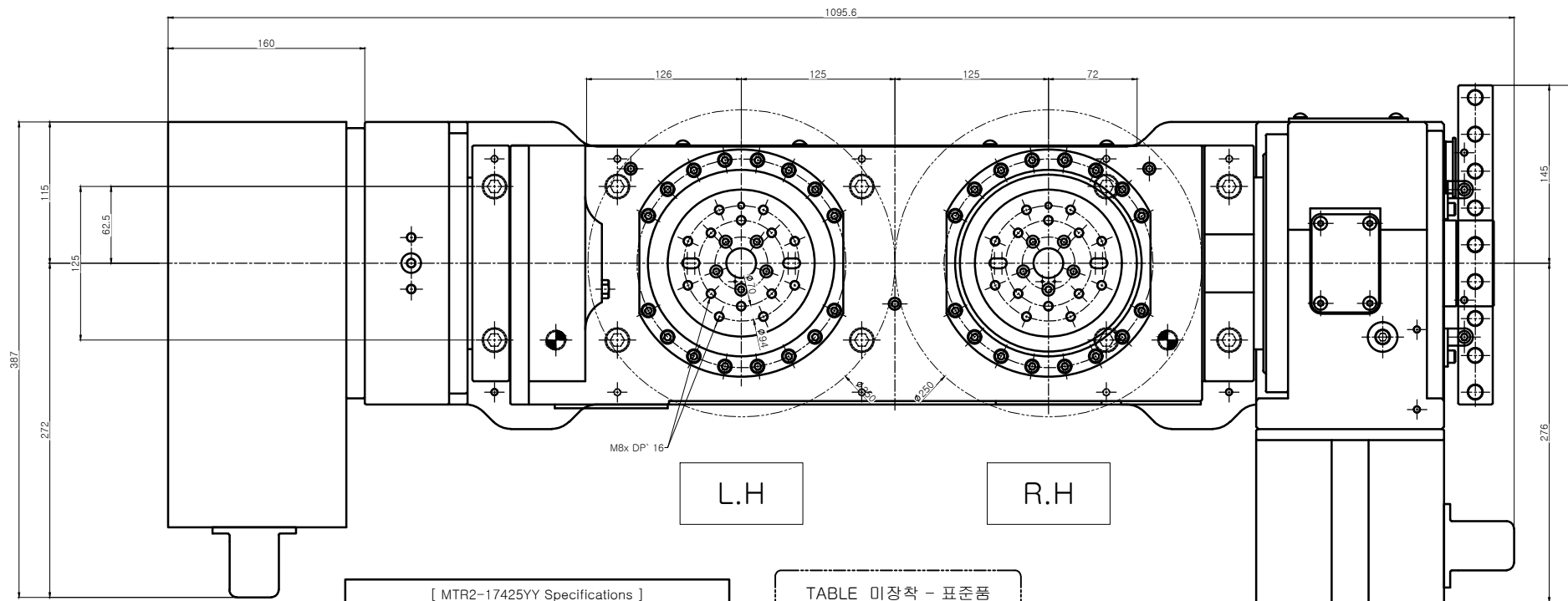
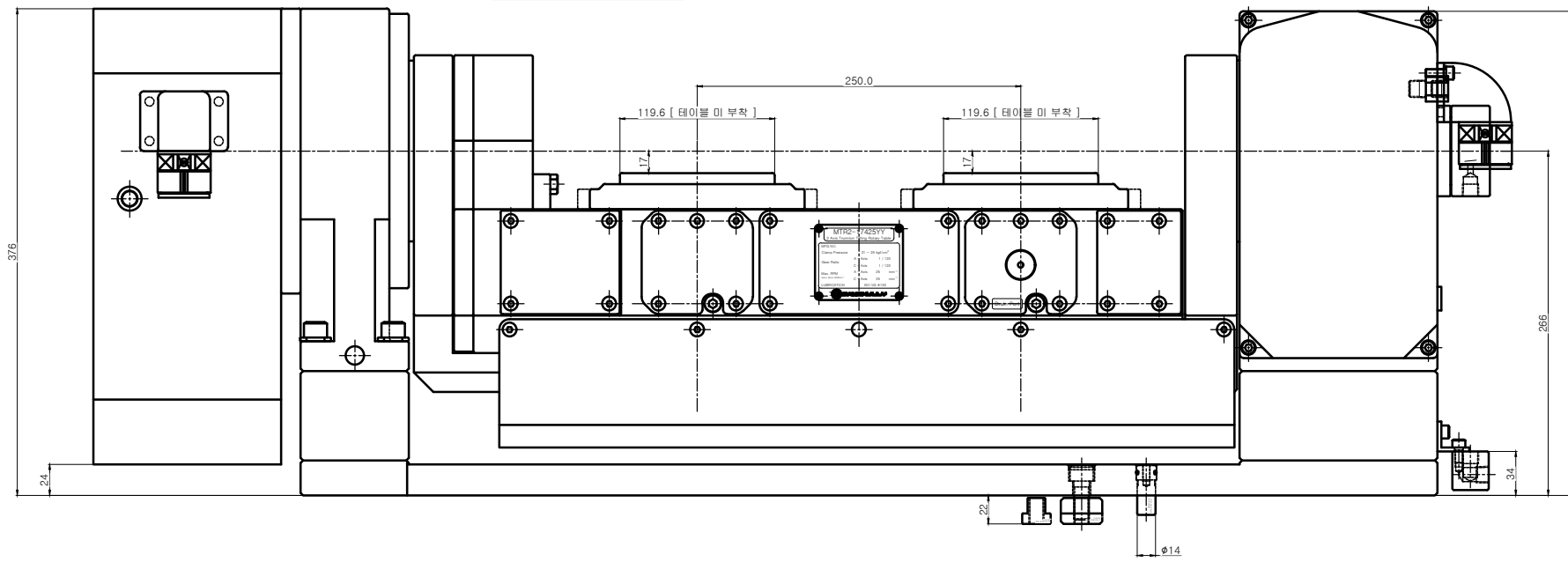
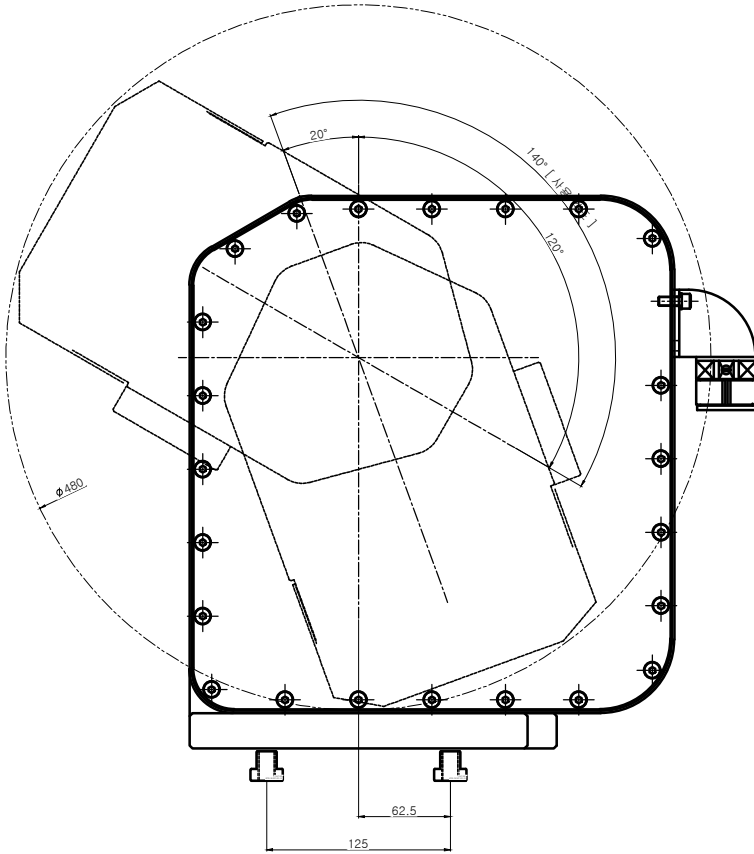

TABLE 미장착 - 표준품

[MTR2-17425YY Specifications]

A축 사양 (경사)		C 축 사양 (회전)	
Tilting Angle	-20° ~ +120°	Rotating Angle	360°
Clamp Force	-	CLAMP FORCE	-
Clamp Pressure	21 ~ 25 kgf/cm ²	Clamp Pressure	21 ~ 25 kgf/cm ²
Gear Ratio	1 / 120	Gear Ratio	1 / 120
Max. RPM	25 (Motor 3000 min ⁻¹)	Max. RPM	25 (Motor 3000 min ⁻¹)
Servo Motor	SGM7P-15A7A6S	Servo Motor	SGM7P-15A7A6S
		Work Weight (kgf)	Left Axis : 40 Right Axis : 40

Weight : - kgf (유압 배관 제외)



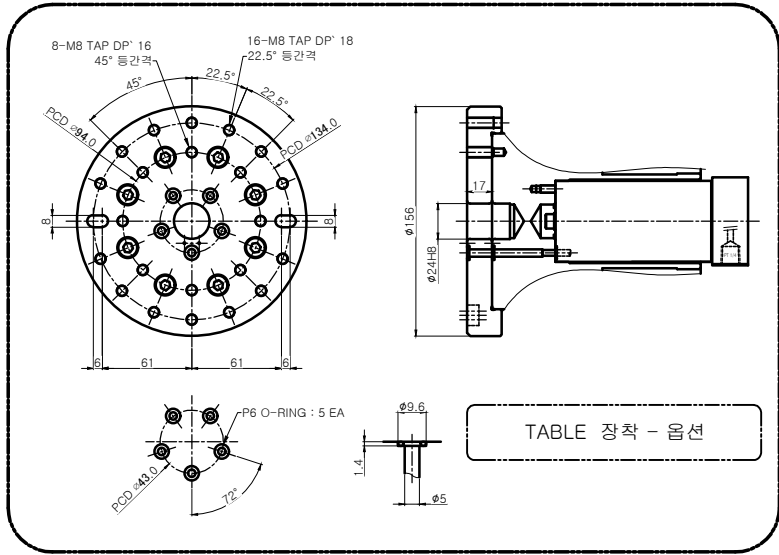

Clmap SPEC.		
Axis	적용 유압력	Piston 추력
S01 A Axis	25 kgf/cm ²	3,060 kgf
S02 C Axis		2,380 kgf
S03 Support Axis		2,190 kgf
Clamp 사용 압력 주의 할 것.		
Clamp 관련 Manifold Label 압력 표기 주의		

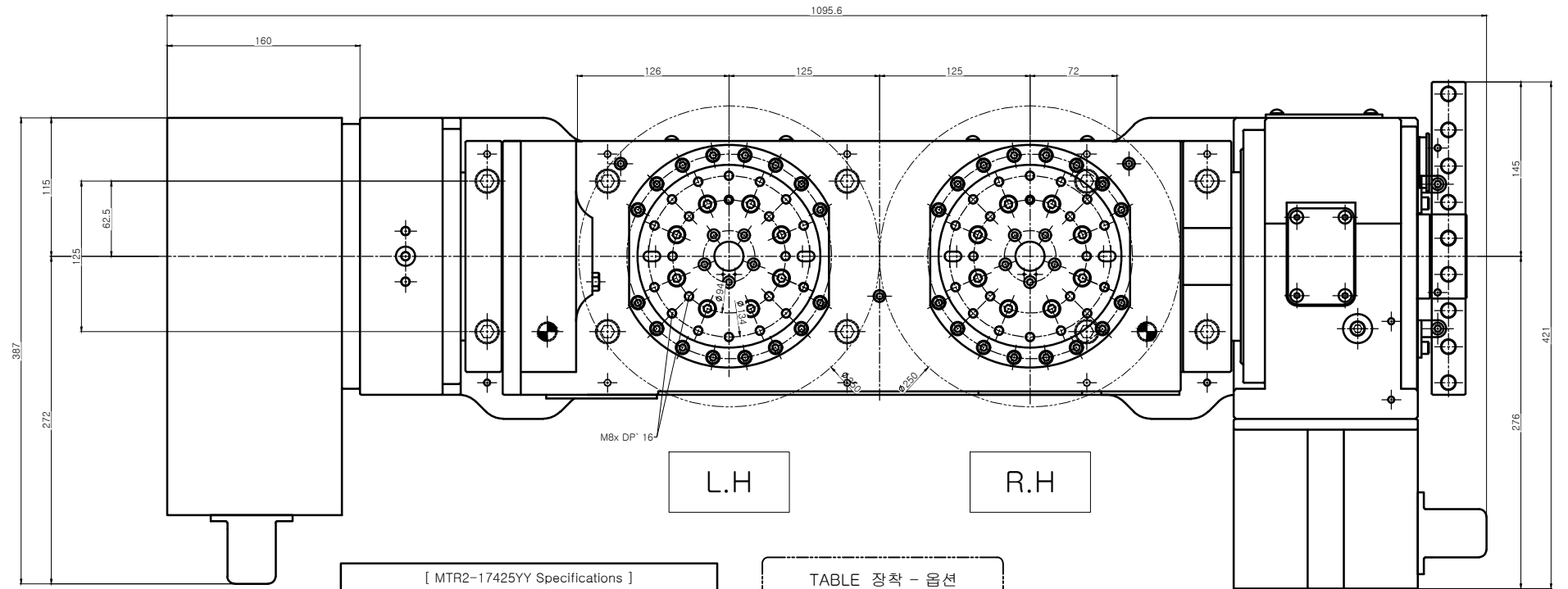

[MTR2-17425YY Specifications]

A축 사양 (경사)		C축 사양 (회전)	
Tilting Angle	-20° ~ +120°	Rotating Angle	360°
Clamp Force	-	CLAMP FORCE	-
Clamp Pressure	21 ~ 25 kgf/cm ²	Clamp Pressure	21 ~ 25 kgf/cm ²
Gear Ratio	1 / 120	Gear Ratio	1 / 120
Max. RPM	25 (Motor 3000 min ⁻¹)	Max. RPM	25 (Motor 3000 min ⁻¹)
Servo Motor	SGM7P-15A7A6S	Servo Motor	SGM7P-15A7A6S
		Work Weight (kgf)	Left Axis : 40 Right Axis : 40

Weight : - kgf (유압 배관 제외)

